

Immersion heater stainless steel fittings



Set for brazing



Set for TIG welding

Brazing assembly description

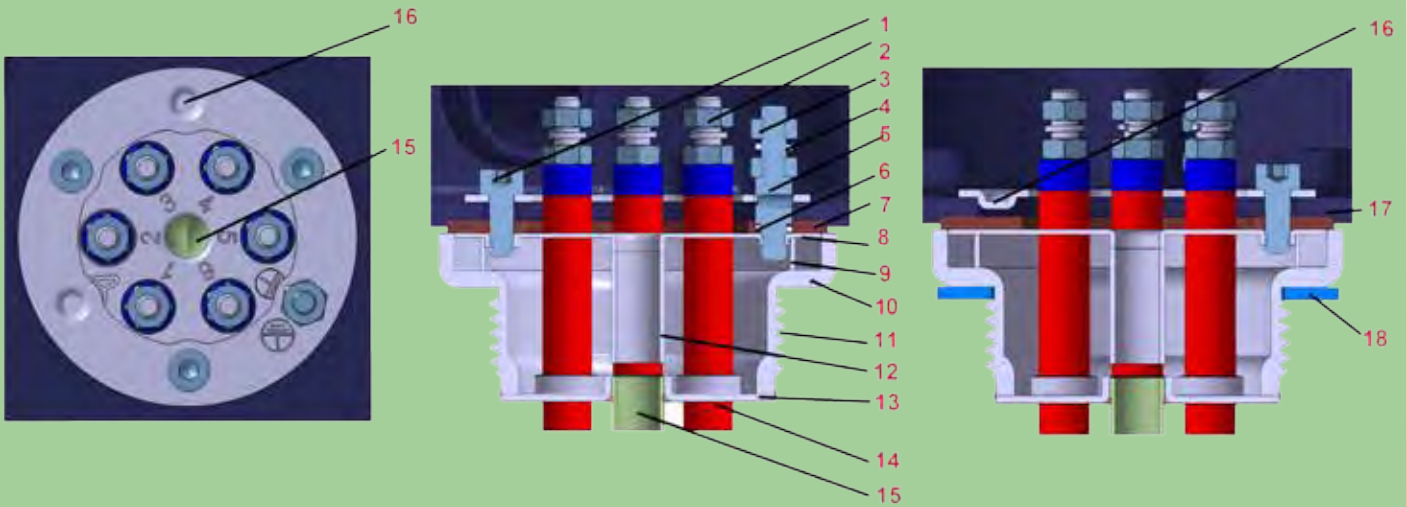

- | | | | |
|------------------------------|---|-------------------------------|---|
| 1: Assembly screw, M4 | 6: Dented washer | 11: Thread with gasket groove | 16: Rotation ring with centering bossings |
| 2: Heating element terminals | 7: Silicone waterproof gasket | 12: Pocket extension | 17: Enclosure |
| 3: Grounding nuts | 8: Hexagonal top plate | 13: Bottom plate | 18: Unlosable fitting gasket |
| 4: Dented washer | 9: Brace | 14: Heating element brazing | |
| 5: Grounding stud M4 | 10: Fitting with machined sealing surface | 15: Pocket tube | |

TIG welding assembly description

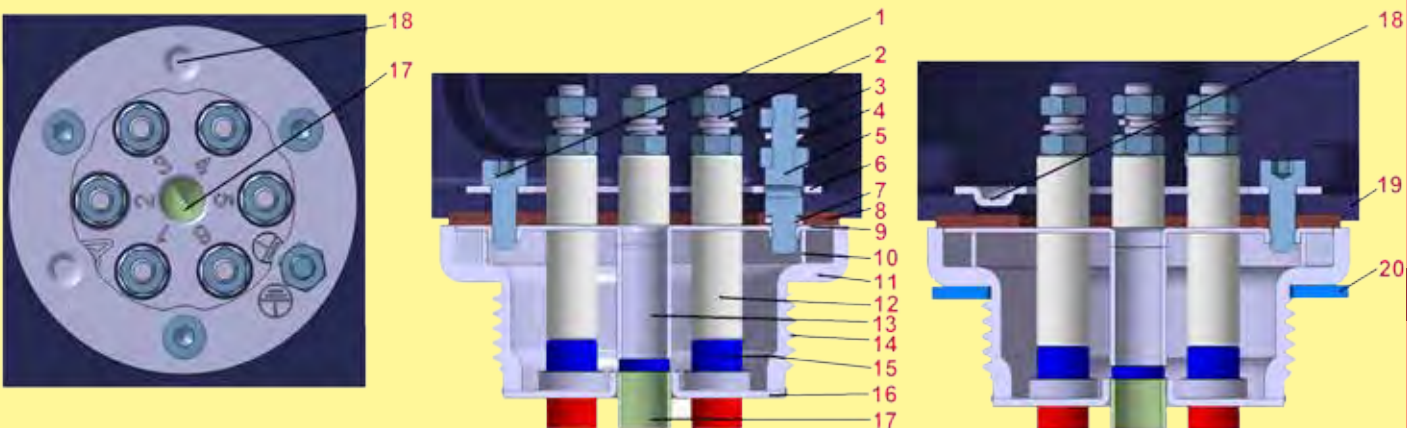

- | | | | |
|-------------------------------|-------------------------------|---|------------------------------|
| 1: Assembly screw, M4 | 6: Rotation ring | 11: Fitting with machined sealing surface | 16: Bottom plate |
| 2: Heating elements terminals | 7: Dented washer | 12: Ceramic spacer | 17: Pocket tube |
| 3: Grounding nuts | 8: Silicone waterproof gasket | 13: Pocket extension | 18: Centering bossings |
| 4: Dented washer | 9: Hexagonal top plate | 14: Thread with gasket groove | 19: Enclosure |
| 5: Grounding stud M4 | 10: Brace | 15: Standard ceramic insulator | 20: Unlosable fitting gasket |

Because of permanent improvement of our products, drawings, descriptions, features used on these data sheets are for guidance only and can be modified without prior advice

