

## Introduction to different soft heating cable technologies

To reflect the maximum temperatures allowed by the insulating polymers, the powers of flexible heating cables are generally between 5 and 30W/meter, exceptionally 40W/m and 60W/m for self-regulating cables. These cables are coiled or laid longitudinally and in contact with the walls to heat. They are held in place by adhesives or metal strips. Classification for fire resistance is governed by EN 60332 Standard.

Main recommendations for the use of flexible heating cables

**Connections :** the heating cable ends must necessarily be connected to a non-heating section before entering the electrical control box.

### Electrical protection :

All heating cables and ribbons must be installed with power protection complying with local regulations. For self regulating cables, the French Standard NFC 15-100 requires a circuit breaker or a GFCI with 30mA magnetic gauge to ensure the protection of persons.

### Specific issues related to current peaks of self-adjusting cables :

These cables cause a significant current surge when they power up when cold. Refer to records of cable manufacturers to check the value.

Therefore, it is important to:

1. To adjust the breaker rating based on that surge (values indicated by the standard CEI60898).
2. Take into account this fact when selecting solid state relays. These surcharges are repetitive when the self-regulating cables are controlled by an external control system, we recommend over sizing SSRs, since repetition of these current peaks limits the lifetime of solid state relays (See above § for solid state relays).

## Series technology



Bare series cable coiled on a fiberglass core

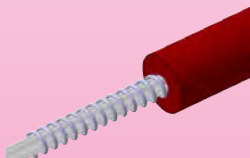

Bare series cable coiled on a fiberglass core with PVC, silicone or FEP (PTFE) insulation

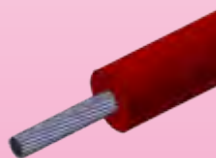

Multi-strand series cable with PVC, silicone or FEP (PTFE) insulation

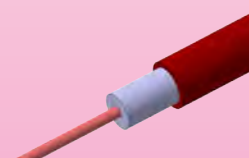

Series cable in metal tubing with magnesia insulation

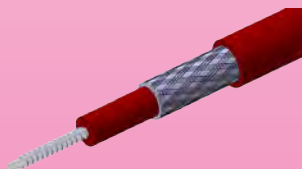

Series cable with metal protection braiding



Series cable with non-heating return conductor



Series cable with two heating conductors

The heating cables are composed of a multi-strand single conductor, the strands can be straight or wound on a fiberglass core. The electrical insulation is typically PVC, Silicone, or FEP. The cables have a circular cross section and can accommodate a metal braid as a mechanical protection that can itself be coated with a flexible insulator. Each cable end is connected to the power supply. They are also available with two parallel conductors, one heating and one not-heating for return connection back, and also with two parallel heating conductors. They are defined by their metric resistance (Ohms / m) to be calculated according to the power and voltage, as well as technical limitations (composition of the strands, the maximum temperature withstood by insulation). Their length cannot be on-site adjusted. Models without protective braid are generally used in the refrigeration industry for defrosting cold room doors, defrost and evaporator flow, freeze protection of pipes, valves, water meters, etc. Models with protective braid are used for heat-tracing of great length pipes in petro chemistry for example.

### Cable ends :

The cable ends must be fitted with a non-heating portion, cable or wires, which may be crimped or soldered, then coated with an insulator (silicone sleeve, heat shrink sleeve or molding: see pages 62-63)

Use heat shrink sleeves with caution for wire terminations if they are PVC, Polyolefin or flexible polymer-type TPR coated.

### Temperature control :

This technology requires a temperature control system. A fixed setting thermostat, mostly a disc thermostat, can be molded at one end of the cable in the two parallel conductor versions (see pages 60-61)

## Constant wattage parallel technology



*Constant wattage cable with protective braid*

These flat ribbon-shaped cables are composed of two non-heating copper conductors delivering the 230V supply over the entire length of the ribbon.

The thermal effect is provided by the flow of current from one conductor to the other through a parallel mesh composed of resistive nickel-chromium wires alternately welded to one and the other of the two conductors. The electrical insulation is typically PVC, polyolefin, silicone, or FEP. The cables are flat section and may receive a mechanical protection by a metal braid which can itself be coated with a flexible insulator. These cords are connected to the power supply at one end, the other end to receive electrical insulation covering the cut.

They are defined by a watts per meter value. This technology allows the cutting of the heating cable to length, with an output directly proportional to the length.

It is adapted to maintain a medium heat, because its resistance does not vary as a function of temperature like for the self-regulating cables, and it is not restricted in temperature by the characteristics of the semiconductor resistive compound in self-regulating cables.

### **Cable ends :**

The cable ends must be fitted with a non-heating portion, cable or wires, which may be crimped or soldered, then coated with an insulation (silicone sleeve, heat shrink sleeve or molding: see pages 103-104)

Use heat shrink sleeves with caution for wire terminations if they are PVC, Polyolefin or flexible polymer-type TPR coated.

### **Temperature control :**

This technology requires a temperature control system. A fixed setting thermostat, mostly a disc thermostat, can be molded at one end of the cable in the two parallel conductor versions (see pages 93)

## Parallel technology, self-regulating type

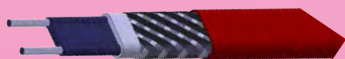

*Self regulating cable with protective metal braid*



*Limiting power cable with spacer between conductors*

These flat ribbon-shaped cables are composed of two non-heating copper conductors (sometimes 3), delivering the power supply over the entire length.

The thermal effect is ensured by an extruded plastic polymer conductor, connecting the two copper conductors.

This polymer main thermal characteristic is the variation in its resistivity and thus its power per linear meter, depending on its temperature. This temperature is the result of its self-heating by Joule effect and its heat exchange outwardly by the wall on which it is placed, as well as the external temperature. The power reduction is in the region of 65% between 0 and 140 ° C (maximum temperature withstood by the polymer semiconductor).

This helps delivering the required power depending on environmental conditions.

This cable is also self-limiting and its power is greatly reduced when approaching the polymer temperature limit, thus avoiding destruction by overheating in the event of improper installation (overlapping or crossing wires, crossing insulation, etc). However, one must ensure that, in any case, the temperature of the fluid flowing in the pipe does not exceed the polymer critical temperature or it would cause its destruction.

The counterpart of this resistivity increase as a function of temperature is a resistivity decrease when the temperature drops. The starting power will be a function of ambient temperature. In the case of very cold environments, this causes large surges until the cable reaches its operating temperature. The startup power will be a function of ambient temperature. In the case of very cold environments, it causes large surges until the cable reaches its operating temperature.

A variant of this technology called power-limiting uses a coiled composite wire around two parallel conductors separated by a spacer of constant width. The characteristics of this wire allow a power limitation as its (.../...) power raises quite strongly with temperature.

# Connection systems for heating cables with silicone filling

## Silicone connection sleeve, type G, for accessories with dia 14 mm tip.

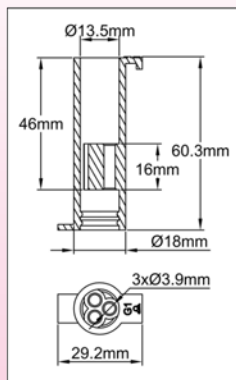
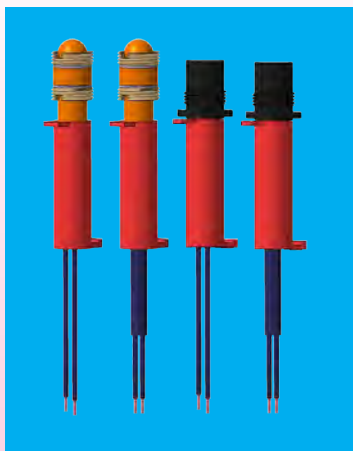

Used to connect two or three conductors or a cable on :

- Anti-freeze thermostat
- Surface mount thermostat
- End Of Line indicator light
- Pt100 sensor
- NTC sensor

When the filling is done according to installation instructions, it provides an IP65 sealing.

After crimping the conductors, fits with a light grip on the 14 mm diameter cylindrical parts of the accessories.

It has a holding tab for filling and a pulling tab to drag it in and internal guidelines that maintain a constant distance between connections when filling.

Average volume of silicon needed for filling: 5 ml (5 cm<sup>3</sup>).

<b>Reference</b>	6YTNG1M140000060
<b>Packaging:</b>	10 pieces bag

## Silicone sleeves type E, for self regulating heating cable end or constant power cable, or two conductors series cable.

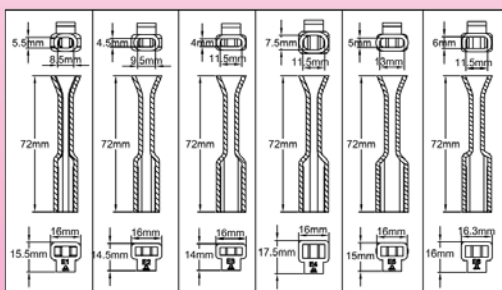
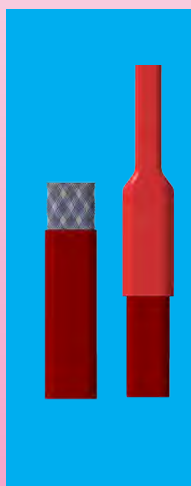

Reference	N°	Hole	Cable gauge
6YTNE1M085055072	E1	8.5 x 5.5	9 x 6 to 9.5 x 6.5
6YTNE2M095045072	E2	9.5 x 4.5	10 x 5 to 10.5 x 5.5
6YTNE3M115040072	E3	11.5 x 4	12 x 4.5 to 12.5 x 5
6YTNE4M115075072	E4	11.5 x 7.5	12 x 8 to 12.5 x 8.5
6YTNE5M130050072	E5	13 x 5	13.5 x 5.5 to 14 x 6
6YTNE6M115060072	E6	11.5 x 6	12 x 6 to 12.5 x 7

Slip by pressing lightly on the unconnected ends of heating cables. When the filling is done according to installation instructions, they provide an IP65 sealing. Include a funnel for easy RTV filling and a holding tab for filling. The square section allows pipe mounting with a wireclamp or clamp. These sleeves can possibly be cut in the middle after polymerization. Average volume of silicone needed for filling: 1.4 ml

Packaging: 10 pieces bag

## Silicone connection sleeve type C for constant power heating cable parallel or self-regulating with protective and grounding metal braid.

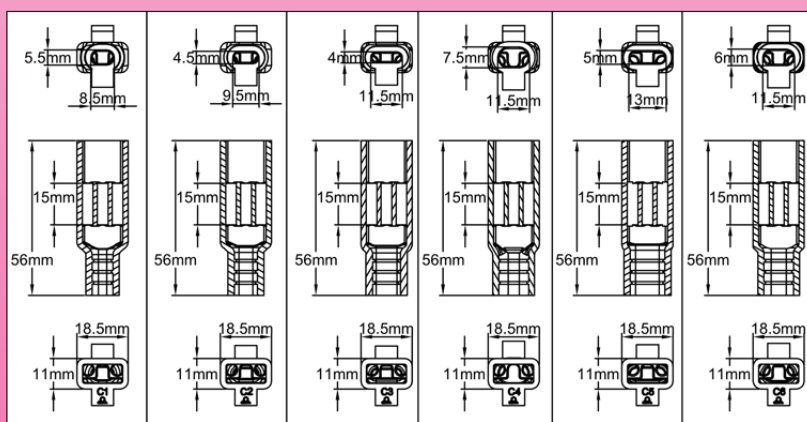
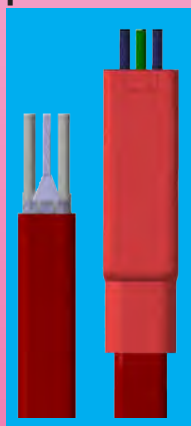

Reference	N°	Hole	Cable gauge
6YTNC13085055056	C1	8.5 x 5.5	9 x 6 to 9.5 x 6.5
6YTNC23095045056	C2	9.5 x 4.5	10 x 5 to 10.5 x 5.5
6YTNC33115040056	C3	11.5 x 4	12 x 4.5 to 12.5 x 5
6YTNC43115075056	C4	11.5 x 7.5	12 x 8 to 12.5 x 8.5
6YTNC53130050056	C5	13 x 5	13.5 x 5.5 to 14 x 6
6YTNC63115060056	C6	11.5 x 6	12 x 6 to 12.5 x 7

They allow the connection of heating cables on non-heating conventional conductors. When the assembly and filling are performed according to installation instructions, they provide an IP65 seal.

Composed of a silicone sleeve adapted to heating cables, 3 x AWG15 wires (1.5 mm<sup>2</sup>) FEP insulated 300V, 300mm length (diameter 2.4 mm), equipped with a cable shoe and a tubular crimp terminal. The connection to the control boxes is made with the M20x1.5 accessories with 2.4mm holes.

Average volume of silicone needed for filling: 1.6 ml

Packaging: 10 pieces bag



## Heating cable end (type E sleeves)



Cut the ribbon to the requested length. Remove 10 to 12 mm of the metal protective braid (if any) in order to ensure a good grip to the silicone. Make sure that none of the wires of this braid exceeds the cut length, which could cause short circuits.



Insert the silicone sleeve on the ribbon end to the stop by pulling the bottom flap.

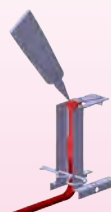

Position the assembly on the filling support and lock it with the upper flap of the sleeve, which has a flange for this purpose. Fill with liquid silicone in the upper shell-hole.



It is possible to cut the insertion and filling flaps after polymerization if necessary.

## Disc thermostat assembly (anti-freeze ofr other set points) on the end of line (type A sleeves)



Cut the ribbon to the requested length. Remove the first protective jacket. Remove 15 to 16mm of the second protective jacket and the metal braid to (if any).



Position the silicone sleeve on the heating ribbon. Strip 4mm on both conductors.



Solder both wires on the disc thermostat terminals. Then slide the sleeve until the thermostat goes to three stop in its place.



Position the assembly on the filling support and lock it with the upper flap of the sleeve, which has a flange for this purpose. Fill with liquid silicone in the upper shell-hole. It is possible to cut the insertion and filling flaps after polymerization if necessary.

## Connection methods for cables accessories with heat shrinkable sleeve



Strip the conductors of 6 to 8 mm, twist them and insert the stripped portion into each tubular connector. If both parts to connect are multi conductor cables, removing the protective jacket must be done on the appropriate length in order to properly slide a heat shrinkable sleeve. If the cable has a metal braid, unbraid it (without cutting any wire) with the tip of a pen or a small metal rod with a rounded end, then group it and twist it in a continuous beam. The conductors and the twisted braid must be the same lengths.

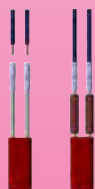

Crimp the tubular connectors with the hexagonal crimp pliers. If the cable has a metal braid, crimp a braid end in a tubular connector. The center of each crimp should be around 4 mm from the edge. Then slide a insulation sleeve on each conductor having a crimped tubular connector. Insert the other element conductors into the second end of the tubular connectors. Crimp. The center of each crimp should be around 4 mm from the edge.



Slide the shrinkable sleeves to a center position on the tubular connectors. Shrink the sleeves one after another with heat gun or a heat source. Do not exceed the shrinking temperature, as this may destroy the sheath or cause cracks.



After checking the integrity of the shrink sleeves, put a heat shrinkable sheath around the cable, on the sleeves, and shrink the same way. Similarly, it is possible to seal the opposite end as follows: If the ribbon has a protective metal braid, remove a few millimeters of its outer jacket to improve the shrinkable sleeve grip. Ensure that no wire of this braid could be in contact with the conductors.